



SmartPack Jr.

Restroom Compactor

*SmartPack Jr. Is Similar In Size To Traditional Trash Bins, But Is **20X More Effective** In Managing Restroom Waste!*

SmartPack Jr. Features:

- "No Touch" Automatic Loading Door That Closes & Locks When Compacting
- Fast 20 Second Cycle Time
- Extremely Quiet 14 dB Noise Level
- "No Rust" Stainless Steel Construction
- Multicolored LED Light Showing Ready for Use, In Use, and Full
- Designed As Both Stand-Alone & Under The Counter Units
- Four Levelers On Base
- Push Button Key Locked Main Cabinet
- Insite Wireless Monitoring

SmartPack Jr. Benefits

- Save 75% on trash related tasks
- Save 30% on trash bags
- 20:1 compaction ratio
- Save On Employee FTE Time, Allowing Them Time For Other, More Important Tasks
- One Compacted Bag Of SmartPack Jr. Waste Replaces 20 Regular 9 Gallon Bags Of Trash!

Ideal Solution For:

- Airports
- Convenience Stores
- Restaurants
- Shopping Malls
- Casinos
- Museums
- Amusement Parks
- Sports Venues
- Universities
- Hospitals



(Under The Counter Model Pictured Above)



SmartPack Jr. Restroom Compactor Drawing & Specifications

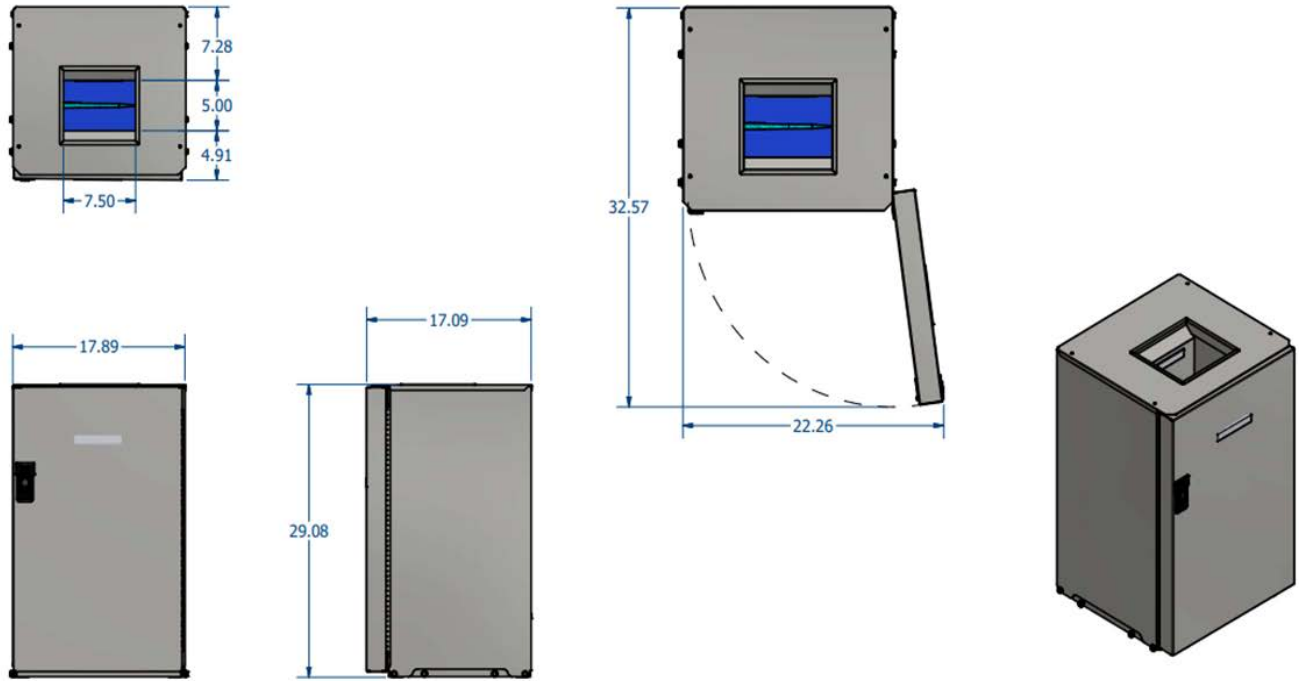

**Digitize Your Waste Handling
With Insite Wireless Monitoring:**



Insite is monitoring technology in SmartPack Jr. that sends alert emails and SMS texts when the unit needs to be emptied or serviced. This provides your staff the extra time to do other important work and saves on trash related accessories! Learn more at <https://harmony1.com/insite-wireless-monitoring/>

SPECIFICATIONS

Exterior	Stainless Steel
Interior	Stainless Steel
Operating Voltage	110V Power 15 Amp Breaker L5-15 Plug
Motor	Nema 23 Step Servo
Cycle Time	Fast 20 Second Cycle Time
Noise Level	Very Quiet 14 dB Noise Level)
Base	Four Leveling Feet

DIMENSIONS

Overall Height	29.25" (743 mm)
Overall Depth	17.25" (438 mm)
Overall Width	18.00" (457mm)
Compactor Weight	155 lbs. (70 kg)
Weight of Full Cube Compacted Waste	10 lbs. (4.5 kg)
Waste Cube Capacity	9 Gallon/34.1L
Required Op. Space	30.00" With Door Open

*Specifications subject to change without notice.



Harmony Enterprises, Inc. 704 Main Avenue North Harmony, MN 55939 USA
1.507.886.6666 international | 1.507.886.6706 fax
Email us at sales@harmony1.com or visit us online at www.harmony1.com

**SmartPack Jr. can be purchased, rented,
or leased. Call (507) 886-6666 or
Email sales@harmony1.com today!**