



Solutions for Waste & Recycling  
**Harmony**<sup>™</sup>  
ENTERPRISES, INC.

# S60XDRC

## Automatic Baling System



The S60XDRC Automatic Baling System is the Ideal Solution For:

- Textile Recyclers
- Commercial Recycling Centers
- Large Industrial Centers
- Scrap Yards
- Redemption Centers

**With it's ultra deep ram penetration, the S60XDRC creates incredibly dense bales each and every time!**

Compare these features of the S60XDRC with the competition:

- Large 7" cylinder
- Fast 40 second cycle time
- Ram penetration to within 10" of the floor produces ultra dense bales
- These bales bring you a higher market value, saving space, money and transportation costs
- It has the power and capacity to quickly and efficiently bale a large variety of materials
- Ability to manually feed various materials through the front door

- Designed for many years of reliable, trouble free service
- Stronger heavy-duty construction than comparable balers
- Making operation more profitable for the user with it's rear hopper and conveyor loading system saving labor and preparation time
- Standard retractable bale dogs for maximum material containment
- Oil cooler standard
- Cylinder safety cable standard on all S60XDRC models.

The S60XDRC Automatic Baling System, another great idea from Harmony Enterprises...

***The Solutions Provider For Waste Handling & Recycling!***



# S60XDRC Automatic Baling System

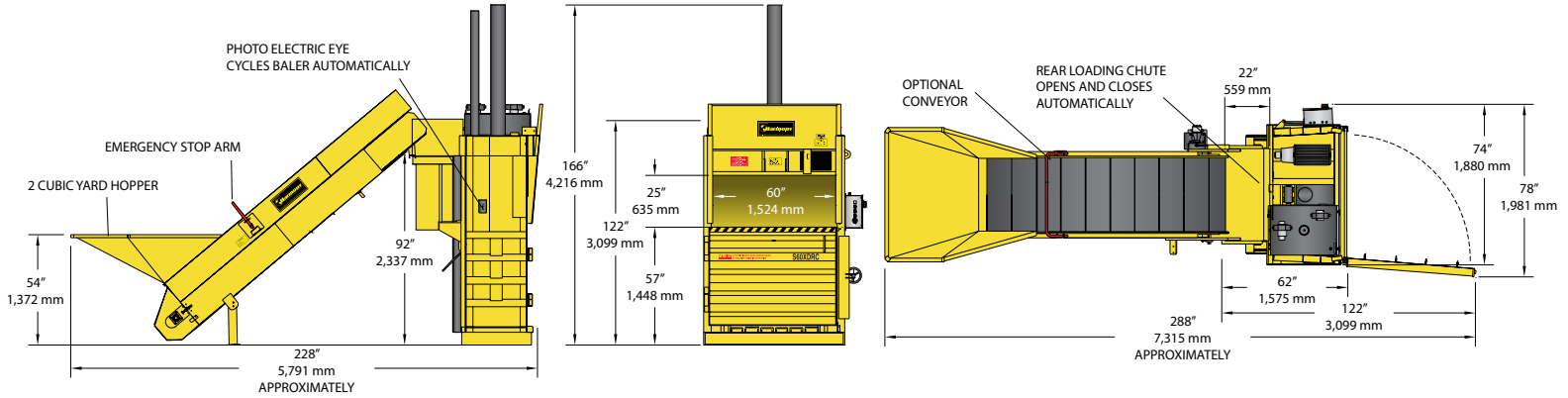

## Standard S60XDRC Features:

- Powerful 7" Cylinder for extra dense bales
- Deep penetration 64" stroke to within 10" from the floor for unequaled bale quality
- Standard retractable bale dogs
- Dual chain ejectors for extra dense bales
- Torque tube to protect cylinder from uneven compaction forces
- Cycles automatically during conveyor loading of material
- No preconditioning of material necessary before baling
- Seven slots for tying bales
- Meets or exceeds all ANSI and OSHA safety standards

## Bale Weights Produced By S60XDRC:

- **OCC: 900-1000 lbs.**
- **PET Bottles: 500-550 lbs.**
- **Aluminum Cans: 350-450 lbs.**

## SPECIFICATIONS

Bale Size	30" x 60" x up to 48" (762 mm x 1,524 mm x up to 1,219 mm)
Ram Pressure @ 2,400	92,360 lbs. (41,894 kg)
System Pressure	2,400 psi
Cycle Time	39 seconds (no load)
Cylinder	7" bore (178 mm) 4.5" rod (114 mm) 64" stroke (1,626 mm)
Motor	20 horsepower, 1,750 RPM, 3 phase
Pump	16 gallons per minute
Electrical Power	208/230/460 volt, 3 phase
Bale Eject	Dual hydraulic chain

## DIMENSIONS WITH CONVEYOR

Loading Door Opening	25" x 60" (635 mm x 1,524 mm)
Unloading Door Opening	57" (1,448 mm)
Overall Height	166" (4,216 mm)
Overall Depth	228" (5,791 mm)
Overall Width	83" (2,108 mm)
Conveyor Belt Width	36" (914 mm)
Depth with Door Open	288" (7,315 mm)
Width with Door Open	88.5" (2,248 mm)
Shipping Height (On side w/cylinder extended)	83" (2,108 mm)
Actual Weight	8,825 lbs. (4,003 kg) with conveyor
Required Operating Area	156 square feet (14.5 square meters)

Specifications subject to change without notice.

