



Solutions for Waste & Recycling
Harmony[™]
 ENTERPRISES, INC.

300SS



450SS



700SS



Inside Stainless Steel Compactors Are The Ideal Solution For:

- Health Care
- School Cafeterias
- Housekeeping Areas
- Quick Serve and Casual Dining Restaurants
- Hotel/Motels
- Education
- Food Service
- Housing Complexes
- Hospitality Firms
- Theme Parks
- Military Bases

Stainless Steel Compactors are the perfect waste control system for high volume waste management.

Compare these features of the Inside Power Packers with the competition:

- **Save 40%-70% on your waste handling bills**
- No need for a special dumpster
- Better security for your business and employees
- Fewer trips to your outside dumpster
- Your waste is compacted up to 1/25th of the original volume
- Power Packer keeps your place of business much neater and cleaner

- Eliminates problems associated with uncovered waste
- Upgrades the appearance of your property by eliminating unsightly piles of waste behind your building
- Lessens fire hazards and complies with health standards
- Up to 25 bags or piles of waste now become one neatly wrapped cube
- Three available models: 300SS, 450SS, and 700SS
- Cycle times: 16 seconds, 21 seconds, and 25 seconds

The Inside Power Packer, another great idea from Harmony Enterprises...*The Undisputed Leader in Quality Manufacturing.*



Stainless Steel Indoor Compactors

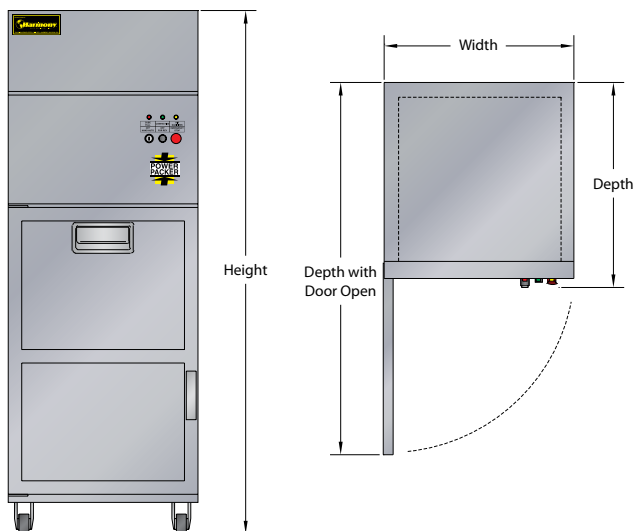

Standard Inside Power Packer Features (all models):

- Control panel is UL® listed
- Heavy-duty cylinder
- Locking key switch
- Cube full indicator light and buzzer
- Air sanitizer
- All stainless steel cabinet
- Hydraulic ejector
- Safety door locks
- Swivel locking front casters and optional drip pan available
- Meets or exceeds all ANSI and OSHA safety standards

MODEL	300SS	450SS	700SS
Height	71" (1,803 mm)	78" (1,981 mm)	78" (1,981 mm)
Width	23" (584 mm)	28" (711 mm)	40" (1,016 mm)
Depth	25" (635 mm)	30" (762 mm)	30" (762 mm)
Depth with Door Open	45" (1,143 mm)	55" (1,397 mm)	67" (1,702 mm)
Loading Door	19" x 16" (483 mm x 406 mm)	24" x 19" (610 mm x 483 mm)	36" x 19" (914 mm x 483 mm)
Cube Capacity	3.3 cubic feet	6 cubic feet	9 cubic feet
Reduction Ratio	up to 25:1	up to 25:1	up to 25:1
Motor	3/4 horsepower	1.5 horsepower	1.5 horsepower
Ram Pressure	9,818 lbs. max (4,453 kg)	14,137 lbs. max (6,412 kg)	25,133 lbs. max (11,400 kg)
Cycle Time	16 seconds	21 seconds	25 seconds
Cylinder Size	2.5" (64 mm)	3" (76 mm)	4" (102 mm)
Electrical Power	115/230 volt	115/230 volt	115/230 volt
Circuit Size	115 volt - 15 amp 230 volt - 20 amp	115 volt - 20 amp 230 volt - 20 amp	115 volt - 30 amp 230 volt - 20 amp
Actual Weight	660 lbs. (299 kg)	980 lbs. (445 kg)	1,280 lbs. (581 kg)
Full Cube Weight	up to 125 lbs. (57 kg)	up to 250 lbs. (113 kg)	up to 350 lbs. (159 kg)

Specifications subject to change without notice.



SAI GLOBAL
ISO 9001
Quality

Three available models:



300SS



450SS



700SS

Harmony Enterprises, Inc. 704 Main Avenue North Harmony, MN 55939 USA
1.800.658.2320 toll free | 1.507.886.6666 international | 1.507.886.6706 fax
Email us at info@harmony1.com or visit us online at www.harmony1.com