

ExtractPack Pro

Liquid Extraction Baler



The **ExtractPack Pro** is the Ideal Solution For:

- Bottlers
- Distributors
- Breweries
- Caterers
- Contract Packers
- Anywhere Out-Of-Date Aluminum, PET, or TetraPak Product Needs To Be Destroyed



Compare These Features Of The ExtractPack Pro With The Competition:

- Creates a standard mill-sized bale of aluminum, PET, & TetraPak.
- Heavy duty stainless steel baling chamber, platen and charge opening
- 254.5 gallon stainless steel liquid reservoir assembly.
- Custom designed stainless steel splash guards, safety covers, and power unit weather cover that have a peaked design to allow for liquid run off.
- Fast 38.5 second cycle time (when empty)
- Water proof magnetically coded safety switches to monitor all gates and doors.
- Allen Bradley PLC
- Space-saving vertical design

- All electrical items are OEM off-the-shelf by design so not waiting around for special orders on replacement items if needed.
- Water proof ultrasonic sensors to monitor charge chamber filling and cycle start operations. No troublesome photo eyes to clean or service.
- Water proof proximity switches to monitor ram locations. No limits switch arms or rollers to keep readjusting.
- All electrical enclosures are stainless steel NEMA 4 rated and all fittings and conduit are non corrosive plastic water tight rated.
- The ExtractPack Pro is constructed with 90% stainless steel, with the remaining 10% structural components painted with "steelit gray" coating to resist corrosion.

ExtractPack Pro Liquid Extraction Baler Product Diagram

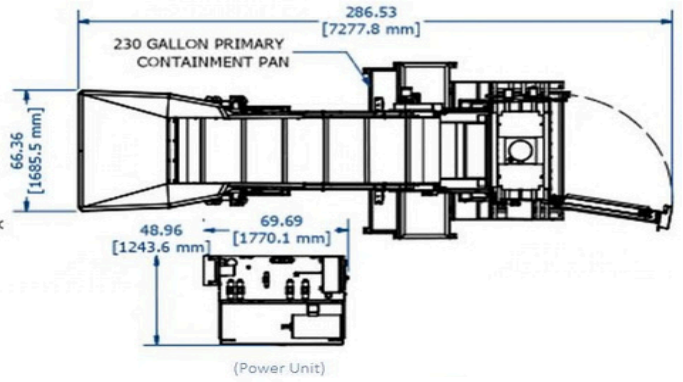
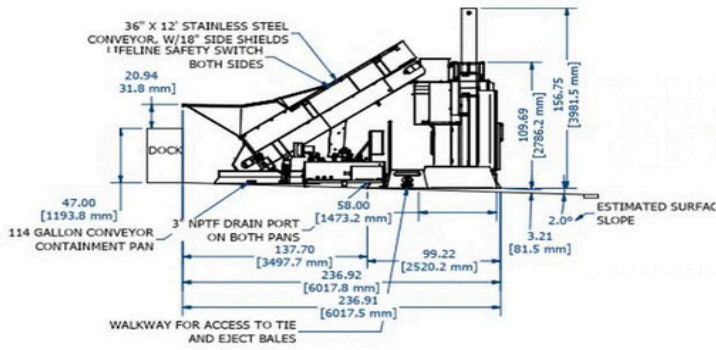

Bale Dimensions:

42" W X 30" D X 30"H

Bale Weights:

Aluminum: 600 lbs.

Each bale uses 42,000-8 oz
aluminum cans or 21,000-12oz
aluminum cans!

PET: 550 lbs.



Harmony's ExtractPack Pro Intermediate Liquid Extraction Baler Meets Or Exceeds OSHA and ANSI Safety Standards.



MODEL	ExtractPack Pro (MAX 42)
Specifications	
Bale Size	30" x 42" x 30" (762 MM x 1,067 MM x 762 MM)
Bale Weight	Aluminum: 600 LBS. (272 KG) PET: 550 LBS. (250 KG)
Platen Force	Extend: 196,350 LBF Retract: 125,644 LBF
Cycle Time	38.5 Seconds
Extend Time	23.5 Seconds
Retract Time	15 Seconds
Electrical Power	208/230/460 Volt, 3 Phase
Motor	20 HP, TEFC
Cylinder	10" (254 MM) Bore, 6" (153 MM) Rod, 52" (1,321 MM) Stroke
Pump	Various Displacement Piston Pump
Liquid Reservoir	254.5 Gallons
Bale Eject	Hydraulic
Bale Tying	Wire or Polyethylene Strap
Dimensions	With Conveyor
Baler Dimensions	77.83"W X 63.29"D X 156.64"H (1,977 MM x 1,608 MM x 3,979 MM)
Loading Door Height	59.25" (1,505 MM)
Overall Height	156.64" (3,979 MM)
Overall Width With Door Open	81.34" (2,066 MM)
Overall Depth With Door Open	285.39" (7,249 MM)
Shipping Height	109.75" (2,788 MM) Upright 78" (1981 MM) On Side
Actual Weight	15,669 LBS. (7,107 KG)
Installation & Operational Area	162 SQ FT (15 SQ M)

**Specifications Subject To Change*



704 Main Ave North, Harmony, MN 55939

(507) 886-6666

