

VC100

Vertical Compactor



The VC100 Is The Ideal Solution For:

- Manufacturing & Industrial Facilities
- Hotels
- Hospitals
- Restaurants
- Convenience Stores
- Retail Stores

Compare These Key Features With The Competition:

- Keylock controls prevent unsafe and unauthorized operation.
- Compaction pressure is held until the next time you are ready to load, ensuring maximum use of space.
- 28,274 lbs of maximum ram force at 2000 PSI.
- Powerful twin 3" Cylinders.
- Powerful and efficient downstroke compaction.
- Innovative design allows it to be ground or chute fed from any angle.
- Available with 2, 4, or 6 Cu. Yard Containers.
- Automatic closing plate to eliminate trash piling up on top of ram.
- Fast 26 second cycle time.
- 4:1 Compaction Ratio
- Indicator Lights For Containers To Assist Haulers.
- Safety switches disable the machine when the loading door is open, preventing injury.
- Remote pendant for easy operation.



VC100 Vertical Compactor

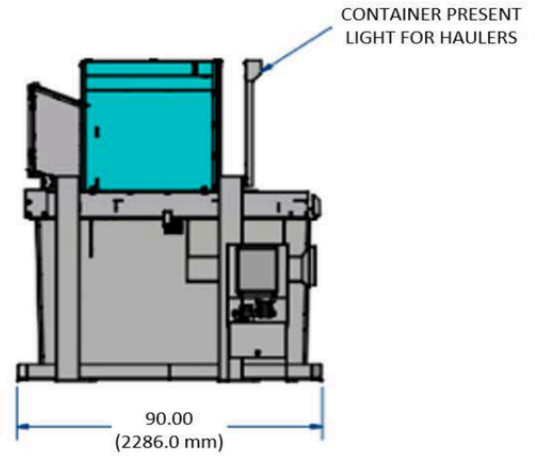
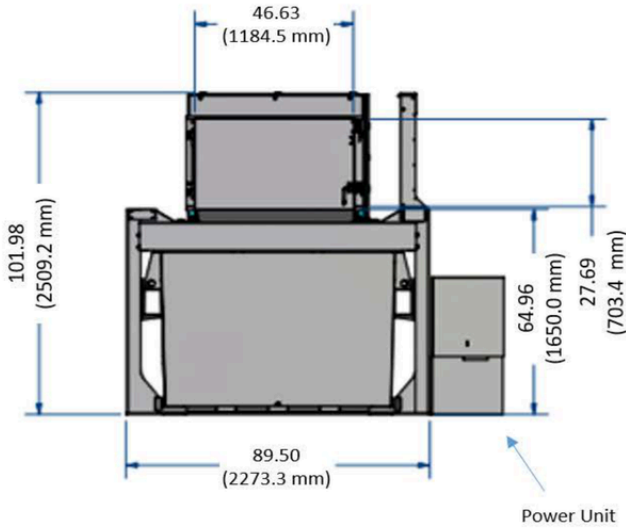

Standard VC100 Features:

- All controls are UL® listed
- Heavy-duty motor and hydraulics for extra long life
- Meets or exceeds all ANSI and OSHA safety standards
- Indicator Lights For Containers To Assist Haulers.
- Optional Sized Containers To Fit Your Specific Needs.



MODEL	VC100
Specifications	
Container Capacity	2, 4, or 6 Cubic Yards
Ram Face	44.63" X 33.75" (1,134 MM X 857 MM)
Ram Force	28,274 LBS. (12,825 KG)
Cycle Time	26 Seconds
Twin Cylinders	3" (76 MM) X 23" (584 MM) Each
Motor	2 HP TEFC
Pump	5.5 GPM Hi/Low Pump
Oil Reservoir	12.5 Gallons
Electrical Power	208/220/460V, Three Phase
Dimensions Compactor	
Load Door Opening	27.69"x 46.63" (703 MM x 1,185 MM)
Overall Height	74.82" (1,900 MM), 86.57" (2,298 MM), 101.98" (2,590 MM)
Overall Depth	90" (2,286 MM)
Overall Width	89.5" (2,273 MM)
Loading Height	38.25" (997 MM), 51" (1,295 MM), 65" (1,651 MM)
Compactor Weight	4,507 LBS. (2,044 KG)
Dimensions Container	
Overall Height 4 & 6 YD	39" (991 MM) - 64.96" (1,650 MM)

*Specifications Subject To Change

