

VC100

Vertical Compactor

The VC100 Vertical Compactor is the Ideal Solution For:

- Manufacturing & Industrial Facilities
- Hotels
- Distribution Centers
- Restaurants
- Hospitals
- Retail Stores
- Convenience Stores



Compare These Key Features With The Competition:

- Keylock controls prevent unsafe and unauthorized operation.
- Compaction pressure is held until the next time you are ready to load, ensuring maximum use of space.
- 28,274 lbs of maximum ram force at 2000 PSI.
- Powerful twin 3" Cylinders.
- Powerful and efficient downstroke compaction.
- Innovative design allows it to be ground or chute fed from any angle.
- Available with 2, 4, or 6 Cu. Yard Containers.
- Automatic closing plate to eliminate trash piling up on top of ram.
- Fast 26 second cycle time.
- 4:1 Compaction Ratio
- Indicator Lights For Containers To Assist Haulers.
- Safety switches disable the machine when the loading door is open, preventing injury.
- Remote pendant for easy operation.



VC100 Vertical Compactor

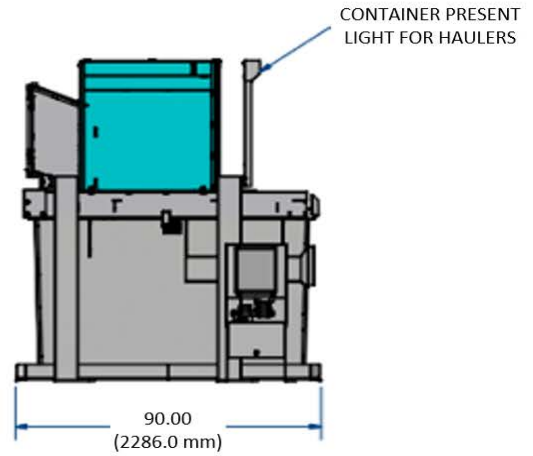
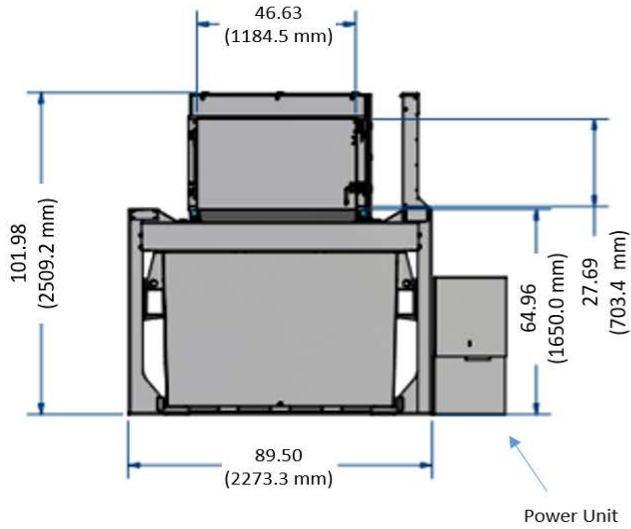

SPECIFICATIONS

Container Capacity	2, 4, or 6 cubic yards
Ram Force	28,274 # ram force at 2000 PSI
Cycle Time	26 seconds
Cylinders	Powerful Twin Cylinders 3" (76 mm) x 2 3.00" (413 mm) Stroke
Motor	2 horsepower, TEFC
Pump	Two-stage
Electrical Power	208/220/460 Volt 3 Phase

DIMENSIONS

Loading Door Opening	27.69"x 46.63" (703.4 x 1184.5 mm)
Container Heights 4yd-6 yd	39" (990.60 mm) - 64.96" (1650 mm)
Overall Height	101.98" (2590.2 mm)
Overall Width	89.5" (2273.3 mm)
Overall Depth	90.00" (2286 mm)
Loading Height	27.69"x 46.63" (703.4 x 1184.5 mm)
Ram Face	44.63" (1133.6 mm) x 33.75" (857.25mm)
Oil Reservoir Capacity	12.5 Gallons

Specifications subject to change without notice.



Standard VC100 Features:

- All controls are UL® listed
- Heavy-duty motor and hydraulics for extra long life
- Meets or exceeds all ANSI and OSHA safety standards
- Indicator Lights For Containers To Assist Haulers.
- Optional Sized Containers To Fit Your Specific Needs.



Harmony Enterprises, Inc. 704 Main Avenue North Harmony, MN 55939 USA
 1.800.658.2320 toll free | 1.507.886.6666 international | 1.507.886.6706 fax
 Email us at info@harmony1.com or visit us online at www.harmony1.com

©2019 Harmony Enterprises, Inc. All rights reserved. Form HEI_P200_US 07/09 SC



VC100

Chute-Fed Vertical Compactor

The VC100 Vertical Compactor is the Ideal Solution For:

- Manufacturing & Industrial Facilities
- Hotels
- Distribution Centers
- Restaurants
- Hospitals
- Retail Stores
- Convenience Stores



Compare These Key Features With The Competition:

- Keylock controls prevent unsafe and unauthorized operation.
- Compaction pressure is held until the next time you are ready to load, ensuring maximum use of space.
- 28,274 lbs of maximum ram force at 2000 PSI.
- Powerful twin 3" Cylinders.
- Powerful and efficient downstroke compaction.
- Innovative design allows it to be ground or chute fed from any angle.
- Available with 2, 4, or 6 Cu. Yard Containers.
- Automatic closing plate to eliminate trash piling up on top of ram.
- Fast 26 second cycle time.
- 4:1 Compaction Ratio
- Indicator Lights For Containers To Assist Haulers.
- Safety switches disable the machine when the loading door is open, preventing injury.
- Remote pendant for easy operation.



VC100 Vertical Chute Fed Compactor

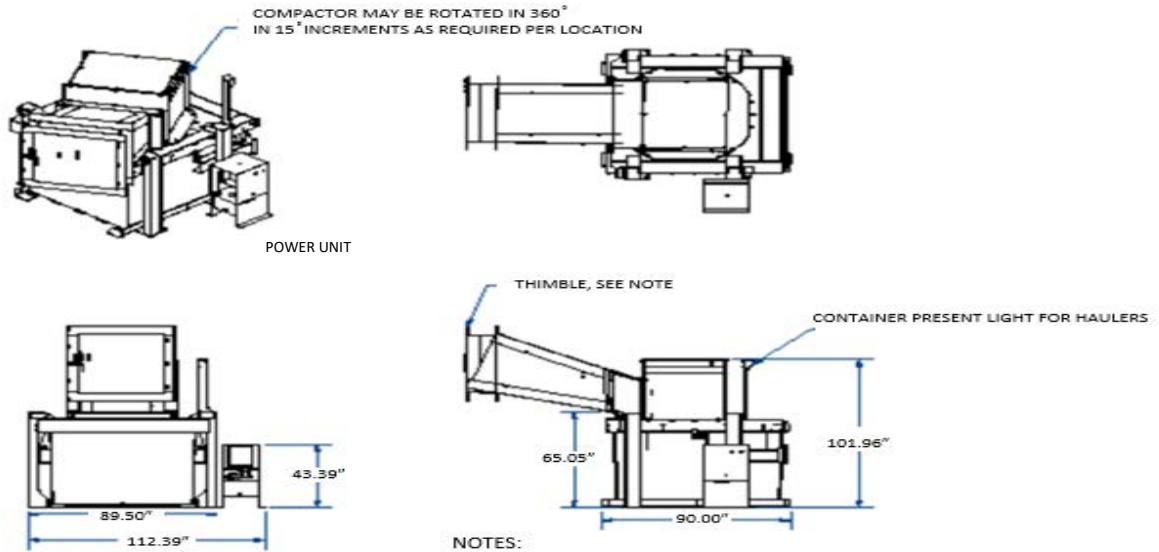

- NOTES:
1. CHUTE TO BE ASSEMBLE ON SITE.
 2. 40" X 40" THIMBLE SHOWN IS SOLD SEPARATELY

SPECIFICATION:

Container Capacity	2, 4, or 6 cubic yards
Ram Force	28,274 # ram force at 2000 PSI
Cycle Time	26 seconds
Cylinders	Powerful Twin Cylinders 3" (76 mm) x 2 3.00" (413 mm) Stroke
Motor	2 horsepower, TEFC
Pump	Two-stage
Electrical Power	208/220/460 Volt 3 Phase

DIMENSIONS

Loading Door Opening	27.69"x 46.63" (703.4 x 1184.5 mm)
Container Heights 4yd-6 yd	39" (990.60 mm) - 64.96" (1650 mm)
Overall Height	101.98" (2590.2 mm)
Overall Width	89.5" (2273.3 mm)
Overall Depth	90.00" (2286 mm)
Loading Height	27.69"x 46.63" (703.4 x 1184.5 mm)
Ram Face	44.63" (1133.6 mm) x 33.75" (857.25mm)
Oil Reservoir Capacity	12.5 Gallons

Specifications subject to change without notice.



Standard VC100 Features:

- All controls are UL® listed
- Heavy-duty motor and hydraulics for extra long life
- Meets or exceeds all ANSI and OSHA safety standards
- Indicator Lights For Containers To Assist Haulers.
- Optional Sized Containers To Fit Your Specific Needs.



Harmony Enterprises, Inc. 704 Main Avenue North Harmony, MN 55939 USA
 1.800.658.2320 toll free | 1.507.886.6666 international | 1.507.886.6706 fax
 Email us at info@harmony1.com or visit us online at www.harmony1.com

©2019 Harmony Enterprises, Inc. All rights reserved. Form HEI_P200_US 07/09 SC

