

VC10

Vertical Compactor

The VC10 Vertical Compactor is the Ideal Solution For:

- Manufacturing Facilities
- Industrial Applications
- Distribution Centers
- Restaurants
- Hospitals
- Hotels
- Convenience Stores



The innovative way to reduce hauling costs and get rid of unsightly trash and the space required for trash storage.

Compare these features of the VC10 with the competition.

- Available with 2, 2.4, 4, or 6 Cu. Yard Containers.
- Our VC10 is designed to reduce trash storage and hauling expenses.
- Fast 26 second cycle time.
- 4:1 Compaction Ratio
- Indicator Lights For Containers To Assist Haulers.
- Safety switches disable the machine when the loading door is open, preventing injury.

- Keylock controls prevent unsafe and unauthorized operation.
- Compaction pressure is held until the next time you are ready to load, ensuring maximum use of space.
- 14,130 lbs of maximum ram force.
- Powerful 3" Cylinder.

The VC10 Vertical Compactor, another great idea from Harmony Enterprises...The Undisputed Leader in Quality Manufacturing.

VC10 Vertical Compactor

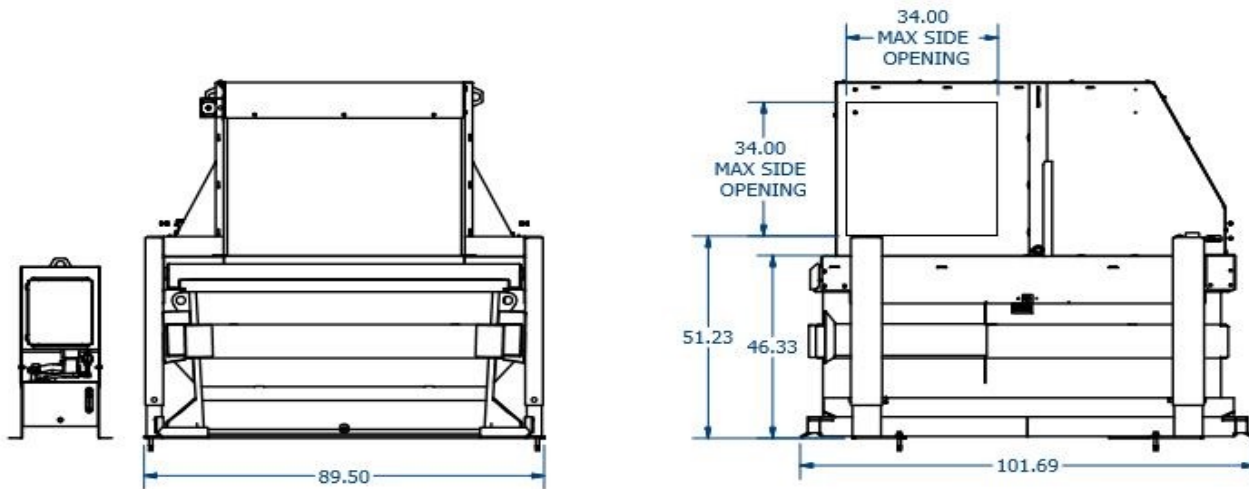

SPECIFICATIONS

Container Capacity	2, 2.4, 4, or 6 cubic yards
Ram Force	14,130 lbs. maximum (11,400 kg)
Cycle Time	26 seconds
Cylinder	3" (76 mm) x 16.25" Stroke (413 mm)
Motor	2 horsepower, TEFC
Pump	Two-stage
Electrical Power	208/220/460 Volt 3 Phase

DIMENSIONS

Loading Door Opening	33"x 48.75" (838 x 1238 mm)
Container Height 6 Cu Yd	57.48" (1460 mm)
Overall Height	100.45" (2551)
Overall Width	89.5" (2273mm)
Overall Depth	101.69" (2583mm)
Chute Feed Opening	34" x 34" (864 mm x 864 mm)
Ram Face	46.88" (1191 mm) x 40.75" (1035 mm)
Oil Reservoir Capacity	12.5 Gallons
Shipping Weight - Compactor	5,100 lbs. (2,313 kg)

Specifications subject to change without notice.

Standard VC10 Features:

- All controls are UL® listed
- Heavy-duty motor and hydraulics for extra long life
- Meets or exceeds all ANSI and OSHA safety standards
- Indicator Lights For Containers To Assist Haulers.
- Optional Sized Containers To Fit Your Specific Needs.



SAI GLOBAL
ISO 9001
Quality

Harmony Enterprises, Inc. 704 Main Avenue North Harmony, MN 55939 USA
1.800.658.2320 toll free | 1.507.886.6666 international | 1.507.886.6706 fax
Email us at info@harmony1.com or visit us online at www.harmony1.com

©2009 Harmony Enterprises, Inc. All rights reserved. Form HEI_P200_US 07/09 SC