

# M30HD

## Vertical Baler



The M30HD Vertical Baler is the Ideal Solution For:

- Convenience Stores
- Office Developments
- Hotels/Motels
- Hospitals/Nursing Homes
- Restaurants
- Department Stores
- Drug Stores

**When space is a problem, let us bale you out with the powerful M30HD Vertical Baler.**

Compare these features of the M30HD with the competition:

- Small size with incredible strength and durability
- Will handle a variety of materials in the harshest of environments
- Fast 37 second cycle time
- Powerful 4½" cylinder with heavy-duty 3" rod for long life
- Energy efficient motor for low operation costs and long life
- Hinged upper-door for extra large feed opening

- Optional chute door makes quick work of high-capacity loading
- Optional locking or non-locking casters for portable use
- Easy access to motor, pump, and all controls for general maintenance

The M30HD Vertical Baler, another great idea from Harmony Enterprises...*The Undisputed Leader in Quality Manufacturing.*



## M30HD Vertical Baler

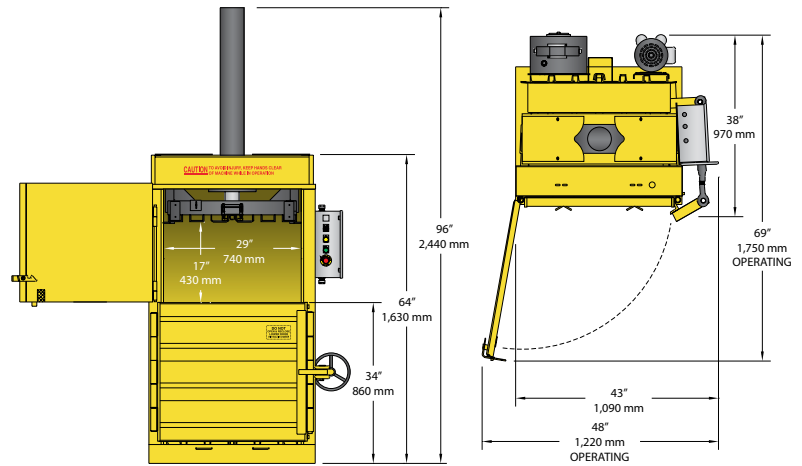

### Standard M30HD Features:

- Control panel is UL® listed
- Four slots for tying bales
- Easy to service and maintain
- Heavy-duty hydraulic ejection
- Turn buckle lock on bale door for safety and opening ease
- Optional removable Crushing Adapter, for crushing large objects such as 5 gallon cans with ease (shown above)
- Optional 16" x 19" chute door
- Meets or exceeds all ANSI and OSHA safety standards

### SPECIFICATIONS

Bale Size	24" x 30" x up to 30" (610 mm x 762 mm x up to 762 mm)
Bale Weight (corrugated)	up to 240 lbs. (109 kg)
Ram Pressure	41,350 lbs. max (18,756 kg)
Cycle Time	37 seconds
Cylinder	4.5" bore (114 mm) 3" rod (76 mm) 33" stroke (838 mm)
Motor	2 horsepower, 1,725 RPM, TEFC
Pump	Two-stage
Electrical Power	115/230 volt, 1 phase, 60 hz
Bale Eject	Hydraulic
Bale Tying	Strapping or polyethylene twine

### DIMENSIONS

Loading Door Opening	17" x 29" (432 mm x 737 mm)
Unloading Door Height	34" (864 mm)
Overall Height	96" (2,438 mm)
Overall Depth	38" (965 mm)
Overall Width	43" (1,092 mm)
Depth with Door Open	69" (1,753 mm)
Width with Door Open	48" (1,219 mm)
Shipping Height	under 80" (2,032 mm)
Shipping Weight	1,475 lbs. (669 kg)
Installation and Operating Area	23 square feet (2.14 square meters)

Specifications subject to change without notice.



SAI GLOBAL  
ISO 9001  
Quality