

Self-Contained Roll-Off Compactors

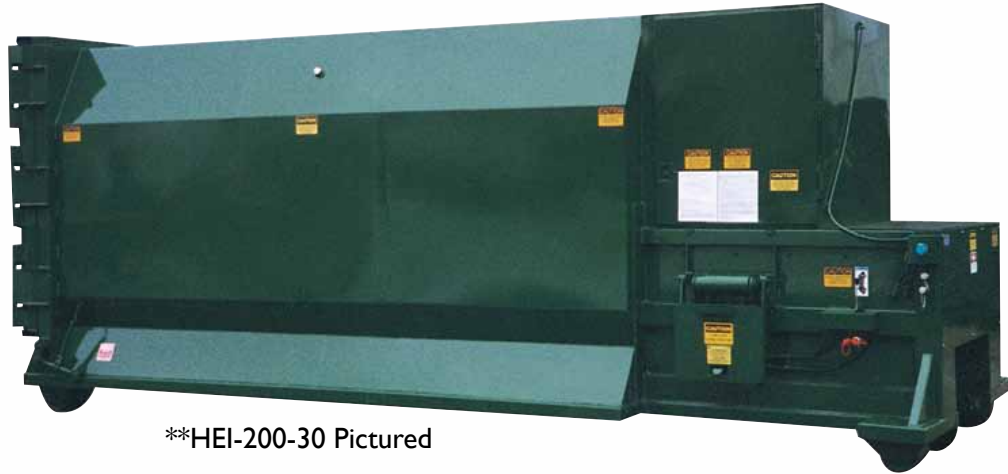

**HEI-200-30 Pictured

Harmony Self-Contained Roll-Off Compactors Are Ideal For Use In:

- Hospitality Industry
- Fast Food Chains
- Department Stores
- Medical Facilities
- Nursing Homes
- Schools and Universities

Anywhere that sanitation and neatness are of the highest importance and space is a concern!

Harmony Enterprises' Self-Contained Compactors are manufactured in a number of sizes, ranging from 9 cubic yards all the way up to 40 cubic yards, and lengths from 13' to 26'.

All of the Self-Contained Compactors combine prime, high quality steel plate, structural steel channel and tubing for some of the strongest compactors available on the market!

All of the Self-Contained Compactors' hydraulic and electrical systems are trusted, name brand components and are of the highest quality available.

Harmony Enterprises' Self-Contained Compactors are built to provide years of reliable, maintenance free service.

COMPACTOR FEATURES

- 3/8" Steel Plate Floor
- 1/4" Steel Plate Side With 4" x 2" x 1/4" Structural Steel Tubing With 6" Channel
- Breaker Bar 6" X 6" X 1/2" Hydraulic Cylinder Mounts
- Replaceable 1/2" UHMW Polyethylene Wear Bars On All Sides, Top And Bottom Of Platen For A Smooth Quiet And Near Frictionless Operation
- Weatherproof Control Panel And Power Pak
- Removable Rear And Top Access Panel

CONTAINER FEATURES

- 3/16" Steel Plate Floor With 6" X 2" X 1/4" Structural Steel Tubing Rails With 2" X 1/2" Steel Bottom Wear Bars
- 3/16" Steel Plate Side, Roof And Door
- Full 3/4" Door Seal
- Side And Bottom Ratchet Latch Door Closer
- Heavy-Duty Door Hinges With Grease Fittings
- Double End Pick-Up
- Tapered Width From 80" At Compactor To 88" At Door (Inside Dimensions)

ELECTRICAL AND HYDRAULIC FEATURES

- (PLC) Controlled Power Unit
- Automatic Single Cycle
- Reverse Button
- Keyed Over-Ride Switch
- Multi Cycle
- 80%-100% Full Lights
- Automatic Shutdown
- 15' Remote
- Fluid Filled Pressure Gauge
- Fluid Inlet Strainer
- Fluid Sump And 15' Hydraulic Hoses
- 4" Side Drain
- Left Or Right Side Hydraulic Connections



HEI-200-30 Self-Contained Roll-Off Compactor

(Other Models Also Available*)

Available Models	Container Size	Charge Chamber
HEI-50-9 Self-Contained Compactor	9 Yard	½ Yard
HEI-100-10 Self-Contained Compactor	10 Yard	1 Yard
HEI-100-15 Self-Contained Compactor	15 Yard	1 Yard
HEI-200-15 Self-Contained Compactor	15 Yard	2 Yard
HEI-200-20 Self-Contained Compactor	20 Yard	2 Yard
HEI-200-30 Self-Contained Compactor	30 Yard	2 Yard
HEI-200-35 Self-Contained Compactor	35 Yard	2 Yard
HEI-200-40 Self-Contained Compactor	40 Yard	2 Yard

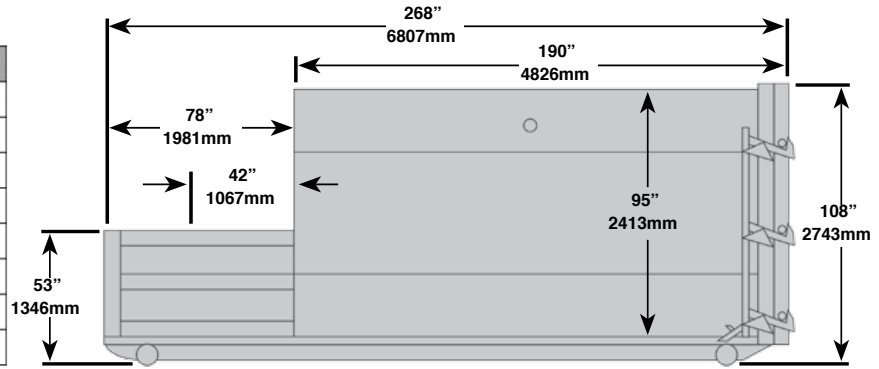

HEI-200-30 Shown Here

Options Available ON HEI-200-30:

- 220V, 7 1/2 HP, IPH
- FLUID RESERVOIR HEATER
- LOW OIL SENSOR
- ENCLOSED DOGHOUSE
WITH DOOR AND INTERLOCK
- WALK-ON OR DRIVE-ON DECK
- WITH 42" SAFETY RAILS
- SIDE LOADING HOPPERS
- THROUGH-THE-WALL CHUTES
- CART DUMPER SYSTEM
- CONTAINER GUIDE RAILS
- OPEN HOPPER
- LOADING DOCK AND GROUND LOADING

SPECIFICATIONS:

OVERALL LENGTH	268" (6807 mm)
OVERALL WIDTH	101" (2565 mm)
OVERALL HEIGHT	108" (2743 mm)
CONTAINER CAPACITY	30 CUBIC YARDS
PLATEN AREA	60" X 44" X 36" (1524 mm X 1118 mm X 914 mm)
COMPACTOR CAPACITY	2 CUBIC YARDS
CHARGE OPENING	42" X 60" (1067 mm X 1524 mm)
RAM PENETRATION	12" (305 mm)
TWIN CYLINDERS	4"X42"X2.5" (102mmX1067mmX64mm)
LINE PRESSURE	2,000 PSI
MAX LINE PRESSURE	2,500 PSI
MAX RAM FORCE	63,000 LBS. (28,576Kg)
CYCLE TIME	45 SECONDS
FLUID CAPACITY	25 GALLONS (95L)
PUMP	10.5 GPM
MOTOR	208/230/460, 10HP, 3PH
APPROX. WEIGHT	10,700 LBS. (4,853Kg)
PAD REQUIREMENTS:	
CONCRETE PAD	120" (3048mm)
MINIMUM LENGTH	336" (8534 mm)
STEEL REINFORCED	6" THICK (152 mm)
MINIMUM	3,000 PSI CONCRETE



Harmony Enterprises
704 Main Avenue North
Harmony, MN 55939

507-886-6666 / info@harmony1.com
www.harmony1.com



Solutions For Waste Handling and Recycling

Specifications subject to change without notice.