

# SmartPack

## Automatic Trash Compactor



- Save 75% on trash related tasks
- Save 30% on existing trash liner usage
- 11:1 compaction ratio
- One compacted bag of trash from a SmartPack replaces 10-12 regular 25 gallon bags of trash

Similar in size and appearance to traditional waste bins, but at least 10 times more effective for managing waste!

The SmartPack Automatic Trash Compactor Ideal For:

See The Video At:

[https://youtu.be/odXd\\_bC0Roo](https://youtu.be/odXd_bC0Roo)

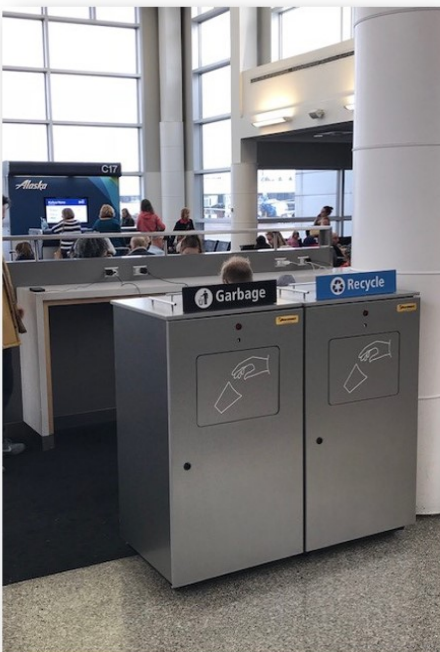

Compare these features of the SmartPack with the Competition:

- "No Touch" Automatic Loading Door
- Quiet 10 Second Cycle Time
- "No Rust" Stainless Steel Chamber
- LED Light Showing Ready for Use, In Use, & Full
- Light, Medium, & Heavy Cube Weight Selector Switch
- Adjustable Photo-eye Sensor To Detect Approaching Patrons
- Adjustable Number Of Door Openings Required To Trigger A Compaction Cycle
- Wheeled Waste Cube With Convenient Pull Strap
- Optional Food Tray Storage Rack
- Variety Of Styles & Colors To Match Any Décor
- Front "Swivel" Casters for Easy Maneuverability
- Programmable Inclination Sensor Detects Precise % of Compactor Fullness In Any Setting! When combined with our *Insite Technology*, you can ensure that every compactor is emptied when its full, optimizing staff time, bag use, and trash related expenses!

- Airports
- Restaurants
- Shopping Malls
- Casinos
- Museums
- Amusement Parks
- Sports Venues
- Universities
- Hospitals



[www.harmony1.com](http://www.harmony1.com)

**Solutions For Waste Handling and Recycling**

## SmartPack Automatic Trash Compactor

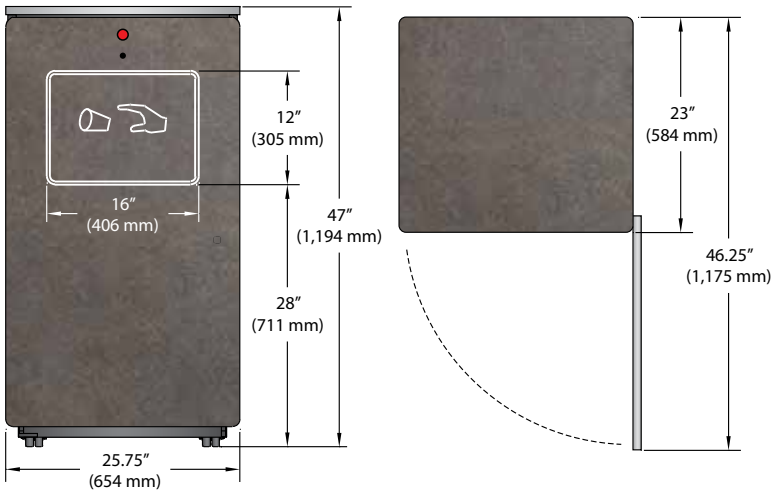

## Portable Wheeled Waste Cube

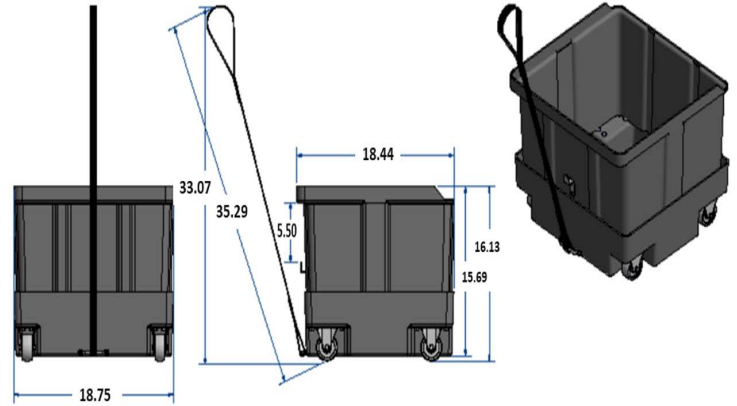

**Make things easier with Insite Wireless Monitoring:**



**Insite is invisible technology in the SmartPack that sends alert emails and SMS texts when the unit needs to be emptied or serviced. This creates extra time for your staff to do other important work and saves on trash related accessories!**

**Learn more at <https://harmony1.com/insite-wireless-monitoring/>**

### SPECIFICATIONS

Exterior	Variety of metal, fiberglass, and laminates to match any decor.
Interior	Stainless Steel Chamber Area
Operating Voltage	115 volt, 60 hz
Motor	1/2 horsepower
Inside Container	Durable plastic 2-pc wheeled waste cube with convenient pull strap
Cycle Time	Quiet 10 second cycle time
Noise Level	Very quiet operation (60 decibels)
Wheels	Heavy-duty recessed casters

### DIMENSIONS

Overall Height	47" (1,194 mm)
Overall Depth	23" (584 mm)
Overall Width	25.75" (654 mm)
Weight	Approximately 450 lbs. (204 kg)
Weight of Compacted Waste	User controlled (ranges from 40-100 lbs.) (18-45 kg) Optional lift cart
Cube Capacity	3.3 cubic feet (94 liters); cubes/cubic yard: Approximately 8 per cycle
Required Floor Space	Approximately 4 square feet (.37 square meters)

Specifications subject to change without notice.



**SmartPacks can be purchased through Harmony Enterprises, or rented through Harmony Equipment Rental!**

Harmony Enterprises, Inc. 704 Main Avenue North Harmony, MN 55939 USA  
1.800.658.2320 toll free | 1.507.886.6666 international | 1.507.886.6706 fax  
Email us at [sales@harmony1.com](mailto:sales@harmony1.com) or visit us online at [www.harmony1.com](http://www.harmony1.com)

**Contact Us today at 507-886-6666 or [sales@harmony1.com](mailto:sales@harmony1.com)**