

AC30

Apartment Compactor



The AC30 Apartment Compactor is the Ideal Solution For:

- Small Apartment Buildings
- Hospitals
- Nursing Homes
- High-Rise Chute Rooms

Solid waste in your building has been brought down to street level with a dedicated waste chute and the AC30.

Compare these features of the AC30 with the competition:

- 31 second cycle time
- 4" cylinder with 2" rod
- Fewer trips to your dumpster
- Compacts into a 2.25 cubic yard container
- Reduces pickups by waste haulers
- Ground level waste pickup
 - Front load or rear load available
 - Small operating space required
 - Saves labor and time
 - Improves business appearance



The AC30 Apartment Compactor, another great idea from Harmony Enterprises...*The Undisputed Leader in Quality Manufacturing.*



AC30 Apartment Compactor

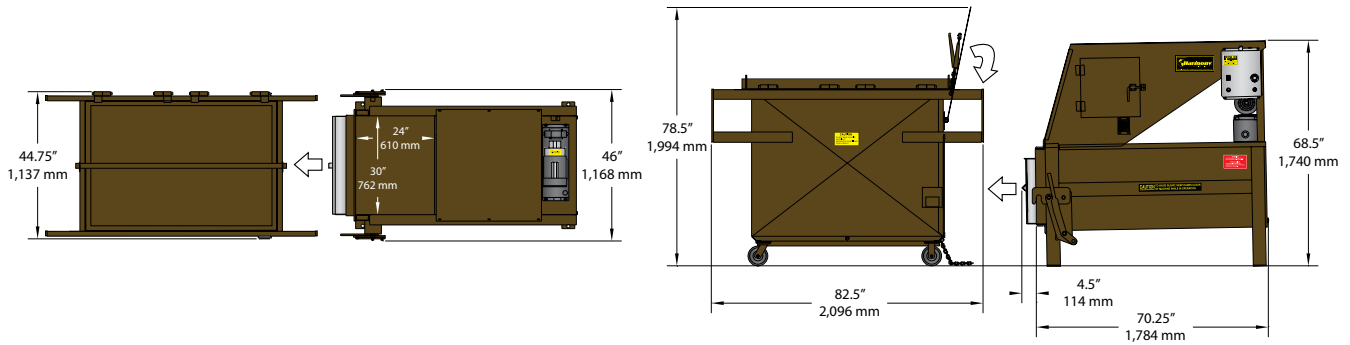

Standard AC30 Features:

- Control panel is UL® listed
- Built to give the system a very long life, assuring little chance of system downtime and repairs
- One-sided container connection system allows the user to connect and disconnect by pulling one lever
- Installation and operating area: 244 square feet (22.7 square meters)
- Meets or exceeds all ANSI and OSHA requirements



SPECIFICATIONS

Container Capacity	2.25 cubic yards
Charge Size	.35 cubic yards
Ram Pressure @ 2,000	25,134 lbs. (11,401 kg)
Ram Penetration	6" (152 mm)
Cycle Time	31 seconds
Cylinder	4" bore (102 mm) 2" rod (51 mm) 30.25" stroke (768 mm)
Motor	2 horsepower, TEFC
Pump	Two-stage
Oil Capacity	3 gallons
Electrical Power	115/230 volt, 1 phase, 60 hz

DIMENSIONS - COMPACTOR

Charge Opening	24" x 30" (610 mm x 762 mm)
Overall Height	68.5" (1,740 mm)
Overall Depth	70.25" (1,784 mm)
Overall Width	46" (1,168 mm)
Shipping Height	68.5" (1,740 mm)
Shipping Weight	760 lbs. (345 kg)

DIMENSIONS - CONTAINER

Overall Height	78.5" (1,994 mm)
Overall Depth	82.5" (2,096 mm)
Overall Width	44.75" (1,137 mm)
Shipping Weight	740 lbs. (336 kg)

Specifications subject to change without notice.



SAI GLOBAL
ISO 9001
Quality