



S60XDRC

Automatic Baling System

The S60XDRC Automatic Baling System is the Ideal Solution For:

- Textile Recyclers
- Commercial Recycling Centers
- Large Industrial Centers
- Scrap Yards
- Redemption Centers

With it's ultra deep ram penetration, the S60XDRC creates incredibly dense bales each and every time.

Compare these features of the S60XDRC with the competition:

- Large 7" cylinder
- Fast 40 second cycle time
- Ram penetration to within 10" of the floor produces ultra dense bales
- These bales bring you a higher market value, saving space, money and transportation costs
- It has the power and capacity to quickly and efficiently bale a large variety of materials
- Ability to manually feed various materials through the front door

- Designed for many years of reliable, trouble free service
- Stronger heavy-duty construction than comparable balers
- Making operation more profitable for the user with it's rear hopper and conveyor loading system saving labor and preparation time

The S60XDRC Automatic Baling System, another great idea from Harmony Enterprises...
The Undisputed Leader in Quality Manufacturing.



S60XDRC Automatic Baling System

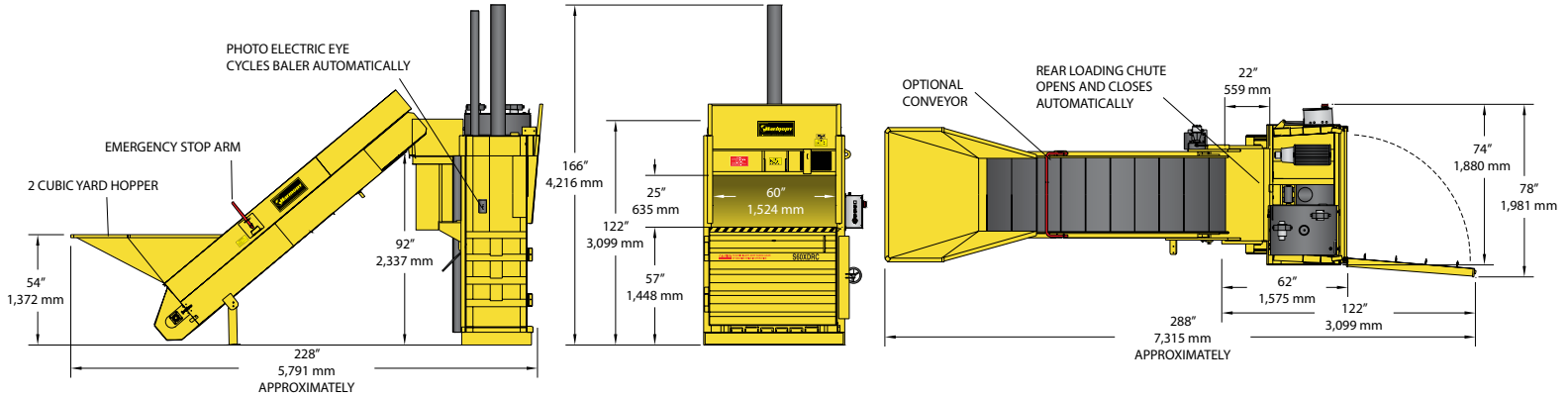

Standard S60XDRC Features:

- **Powerful 7" Cylinder for extra dense bales**
- **Deep penetration 64" stroke to within 10" from the floor for unequaled bale quality**
- **Standard retractable bale dogs**
- **Dual chain ejectors for extra dense bales**
- **Torque tube to protect cylinder from uneven compaction forces**
- **Cycles automatically during conveyor loading of material**
- **No preconditioning of material necessary before baling**
- **Seven slots for tying bales**
- **Meets or exceeds all ANSI and OSHA safety standards**

SPECIFICATIONS

Bale Size	30" x 60" x up to 48" (762 mm x 1,524 mm x up to 1,219 mm)
Ram Pressure @ 2,400	92,360 lbs. (41,894 kg)
System Pressure	2,400 psi
Cycle Time	39 seconds (no load)
Cylinder	7" bore (178 mm) 4.5" rod (114 mm) 64" stroke (1,626 mm)
Motor	20 horsepower, 1,750 RPM, 3 phase
Pump	16 gallons per minute
Electrical Power	208/230/460 volt, 3 phase
Bale Eject	Dual hydraulic chain

DIMENSIONS WITH CONVEYOR

Loading Door Opening	25" x 60" (635 mm x 1,524 mm)
Unloading Door Opening	57" (1,448 mm)
Overall Height	166" (4,216 mm)
Overall Depth	228" (5,791 mm)
Overall Width	74" (1,880 mm)
Conveyor Belt Width	36" (914 mm)
Depth with Door Open	288" (7,315 mm)
Width with Door Open	78" (1,981 mm)
Shipping Height	122" (3,099 mm)
Actual Weight	8,825 lbs. (4,003 kg) with conveyor
Required Operating Area	156 square feet (14.5 square meters)

Specifications subject to change without notice.



Harmony Enterprises, Inc. 704 Main Avenue North Harmony, MN 55939 USA
 1.800.658.2320 toll free | 1.507.886.6666 international | 1.507.886.6706 fax
 Email us at info@harmony1.com or visit us online at www.harmony1.com