



# P200

## Power Packer

The P200 Power Packer is the Ideal Solution For:

- Manufacturing Facilities
- Industrial Applications
- Distribution Centers
- Restaurants
- Hospitals
- Hotels
- Convenience Stores

**The innovative way to reduce hauling costs and get rid of unsightly trash and the space required for trash storage.**

Compare these features of the P200 with the competition:

- Available with front load and rear load containers
- 7½ to 1 compaction ratio
- Our P200 is designed to reduce trash storage and pick-up expense
- Fast 28 second cycle time
- The unique counter-balanced loading door is easy to open
- Safety switches disable the machine when the loading door is open, preventing injury

- Key lock controls prevent unsafe, unauthorized operation
- Compaction pressure is held until the next time you need to load, the end result is more room to load more solid waste
- Our P200 can also be supplied with a feed chute giving increasing flexibility in loading and site location
- Dual cylinders produce 34,000 lbs. of maximum ram pressure
- 3" twin cylinders

The P200 Power Packer, another great idea from Harmony Enterprises... *The Undisputed Leader in Quality Manufacturing.*



## P200 Power Packer



Container Support System

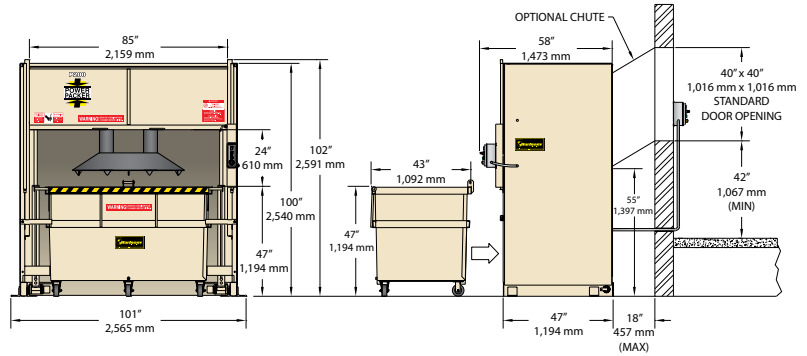

### Standard P200 Features:

- All controls are UL® listed
- When the compaction plate begins its downward pressure against the waste material the Container Support System pushes upward to relieve stress on the floor and the casters of the container
- The Power Packers two-yard container is available in either a front loading or rear loading version
- Heavy-duty motor and hydraulics for extra long life
- Optional Air Sanitizer eliminates odor problems
- Meets or exceeds all ANSI and OSHA safety standards

### SPECIFICATIONS

Container Capacity	2 cubic yards
Ram Pressure	34,000 lbs. maximum (15,422 kg)
Cycle Time	28 seconds
Twin Cylinders	3" bore (76 mm) 1.5" rod (38 mm) 37.5" stroke (953 mm)
Motor	2 horsepower, TEFC
Pump	Two-stage
Electrical Power	115/230 volt, 1 phase, 60 hz

### DIMENSIONS

Loading Door Opening	85" x 24" (2,159 mm x 610 mm)
Container Height	47" (1,194 mm)
Overall Height	102" (2,591 mm)
Overall Width	101" (2,565 mm)
Overall Depth	58" (1,473 mm)
Load Opening	85" x 24" (2,159 mm x 610 mm)
Ram Face	48" x 27" (1,219 mm x 686 mm)
Oil Reservoir	6 gallons
Shipping Weight	
- Compactor	3,250 lbs. (1,474 kg)
- Container	734 lbs. (333 kg)

Specifications subject to change without notice.



Harmony Enterprises, Inc. 704 Main Avenue North Harmony, MN 55939 USA  
 1.800.658.2320 toll free | 1.507.886.6666 international | 1.507.886.6706 fax  
 Email us at [info@harmony1.com](mailto:info@harmony1.com) or visit us online at [www.harmony1.com](http://www.harmony1.com)

©2009 Harmony Enterprises, Inc. All rights reserved. Form HEI\_P200\_US 07/09 SC