

POWER PACKER



The Power Packers are the Ideal Solution For:

- Restaurants
- Schools
- Hospitals
- Retail
- Convenience Stores
- Grocery Stores
- Hotels/Motels

The Power Packers liquid-tight design means that both “wet” and “dry” waste can be compacted and held for disposal in a neat and sanitary fashion.

Compare these features of the Power Packers with the competition:

- Compacting your trash tightly with more than 25,000 pounds of packing force
- Your trash hauler stops less often, and as a result you save money
- A dual interlock system on the loading door and keylock controls that prevent unsafe and unauthorized operation

- The Maximizer option creates more room to load more waste
- 4 to 1 compaction ratio
- 20 second cycle time reduces your work time
- Twin hydraulic cylinders

The Power Packer, another great idea from Harmony Enterprises...
The Undisputed Leader in Quality Manufacturing.



Power Packer



P6RL

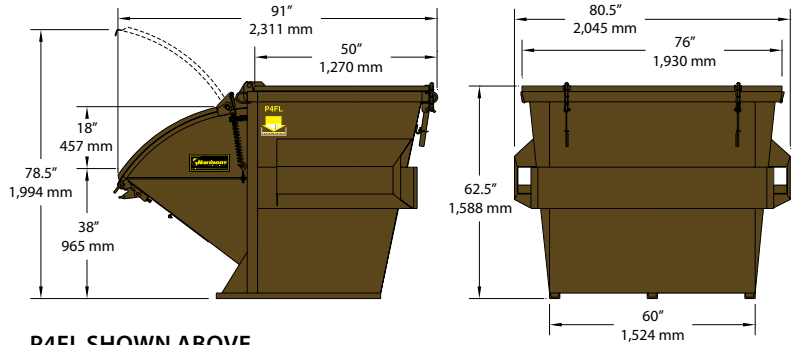

P4FL SHOWN ABOVE

Standard Power Packer Features (all models):

- All controls are UL® Listed
- Standard brown finish with custom colors available
- Leak-proof container to 17"
- Protective Power Unit cover
- Dual Safety Interlock
- Hydraulic interlock prevents operation when loading door is open
- Mechanical interlock prevents opening of door during compaction cycle
- The Maximizer gives you more room to load more solid waste by maintaining pressure until the next load is deposited
- Meets or exceeds all ANSI and OSHA safety standards

MODEL	P4FL	P6FL	P6RL
Container Capacity	4 cubic yards	6 cubic yards	6 cubic yards
Ram Face	53" x 44.5" (1,346 mm x 1,130 mm)	53" x 44.5" (1,346 mm x 1,130 mm)	53" x 44.5" (1,346 mm x 1,130 mm)
Ram Penetration	0 - 14" (356 mm)	0 - 14" (356 mm)	0 - 14" (356 mm)
Packing Pressure	1,800 psi	1,800 psi	1,800 psi
Packing Force	25,450 lbs. (11,544 kg)	25,450 lbs. (11,544 kg)	25,450 lbs. (11,544 kg)
Cycle Time	20 seconds	20 seconds	20 seconds
Hydraulic Cylinders	Twin 3" bore (76 mm) 1.5" rod (38 mm) 16.25" stroke (413 mm)	Twin 3" bore (76 mm) 1.5" rod (38 mm) 16.25" stroke (413 mm)	Twin 3" bore (76 mm) 1.5" rod (38 mm) 16.25" stroke (413 mm)
Height	62.5" (1,588 mm)	62.5" (1,588 mm)	62.5" (1,588 mm)
Width	80.5" (2,045 mm)	80.5" (2,045 mm)	78" (1,981 mm)
Length	91" (2,311 mm)	103" (2,616 mm)	143" (3,632 mm)
Loading Chamber Height	38" (965 mm)	38" (965 mm)	38" (965 mm)
Loading Chamber Opening	27" x 53.5" (686 mm x 1,359 mm)	27" x 53.5" (686 mm x 1,359 mm)	27" x 53.5" (686 mm x 1,359 mm)
Loading Chamber Size	1 cubic yard	1 cubic yard	1 cubic yard
Shipping Weight	2,200 lbs. (998 kg)	2,300 lbs. (1,043 kg)	2,400 lbs. (1,089 kg)

Specifications subject to change without notice.

POWER UNIT

Electric Motor	2 horsepower 115/230 volt, 1 phase, 60 hz
Hydraulic Pump	Two-stage
Hydraulic Reservoir	15 gallons
Hydraulic Hoses	13' with quick disconnect couplers

Specifications subject to change without notice.



Harmony Enterprises, Inc. 704 Main Avenue North Harmony, MN 55939 USA
 1.800.658.2320 toll free | 1.507.886.6666 international | 1.507.886.6706 fax
 Email us at info@harmony1.com or visit us online at www.harmony1.com