



M30STD

Vertical Baler

The M30STD Vertical Baler is the Ideal Solution For:

- Convenience Stores
- Office Developments
- Hotels/Motels
- Hospitals/Nursing Homes
- Restaurants
- Department Stores

When space is a problem, let us bale you out with the powerful M30STD Vertical Baler.

Compare these features of the M30STD with the competition:

- Small size with incredible strength and durability
- Will handle a variety of materials in the harshest of environments
- Fast 23 second cycle time
- Powerful 3" cylinder with heavy-duty 2" rod for long life
- Energy efficient motor for low operation costs and long life

- Hinged upper-door for extra large feed opening
- Locking or non-locking casters for portable use
- Easy access to motor, pump and all control for general maintenance

The M30STD Vertical Baler, another great idea from Harmony Enterprises...*The Undisputed Leader in Quality Manufacturing.*



M30STD Vertical Baler

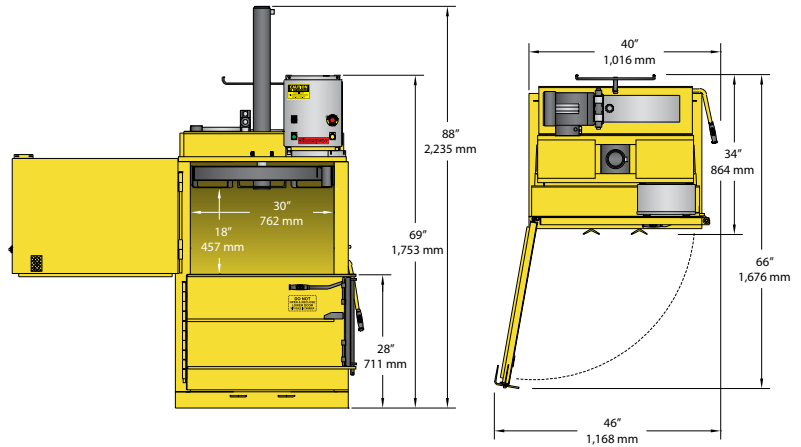

Standard M30STD Features:

- Control panel is UL® listed
- Manual lever for bale eject
- Energy efficient motor for low operating costs and long life
- Easy to service and maintain
- Meets or exceeds all ANSI and OSHA safety standards

SPECIFICATIONS

Bale Size	30" x 24" x up to 24" (762 mm x 610 mm x up to 610 mm)
Bale Weight (corrugated)	up to 145 lbs. (66 kg)
Ram Pressure	14,138 lbs. max (6,413 kg)
Cycle Time	23 seconds
Cylinder	3" bore (76 mm) 2" rod (51 mm) 32.25" stroke (718 mm)
Motor	2 horsepower, 1,725 RPM, TEFC
Pump	Two-stage
Electrical Power	115/230 volt, 1 phase, 60 hz
Bale Eject	Manual lever
Bale Tying	Strapping or polyethylene twine

DIMENSIONS

Loading Door Opening	18" x 30" (457 mm x 762 mm)
Unloading Door Height	28" (711 mm)
Overall Height	88" (2,235 mm)
Overall Depth	34" (864 mm)
Overall Width	40" (1,016 mm)
Depth with Door Open	66" (1,676 mm)
Width with Door Open	46" (1,168 mm)
Shipping Height	69" (1,753 mm)
Shipping Weight	1,045 lbs. (474 kg)
Installation and Operating Area	21.1 square feet (2 square meters)

Specifications subject to change without notice.



ENVIRONMENTAL INDUSTRY ASSOCIATION

Harmony Enterprises, Inc. 704 Main Avenue North Harmony, MN 55939 USA
 1.800.658.2320 toll free | 1.507.886.6666 international | 1.507.886.6706 fax
 Email us at info@harmony1.com or visit us online at www.harmony1.com

©2009 Harmony Enterprises, Inc. All rights reserved. Form HEI_M30STD_US 03/10 SC