

C36RC C36TC

High-Rise System



The C36 High-Rise System is the Ideal Solution For:

- Office Buildings
- Hospitals
- Hotels
- Apartment Buildings

Solid waste in your building has been brought down to street level with the C36 High-Rise System.

Compare these features of the C36 with the competition:

- Cycle times: 36 seconds (C36RC), 29 seconds (C36TC)
- Dramatically lowers waste handling costs with a 10:1 compaction ratio
- 75% reduction in collection and transport frequency
- Reduce pull charges up to 35%
- Less trips to the dumpster
- Higher level of security for you people and tenants
- Much lower labor costs

- Neater and cleaner property with fewer fire hazards
- Easy access to manually load solid waste directly into the chamber
- Waste compacted into heavy-duty bags
- Minimal overall footprint requires less floor space for operation
- Optional time saving carts available

The C36 High-Rise System, another great idea from Harmony Enterprises...*The Undisputed Leader in Quality Manufacturing.*



C36 High-Rise System

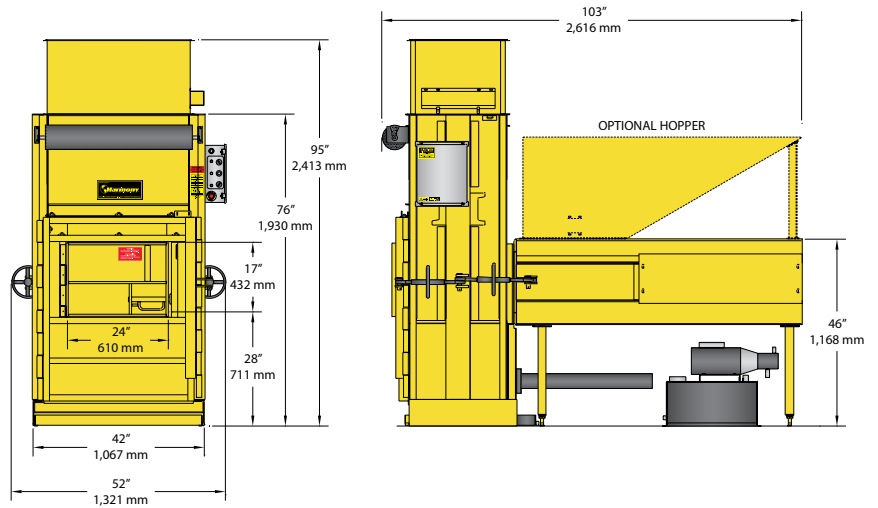

Standard C36 Features:

- Control panel is UL® listed
- 9 cubic feet cube size
- Cube weights up to 350 pounds
- Hydraulic cube eject
- Automatic cube eject system eliminates the physical effort to remove full cubes
- Meets or exceeds all ANSI and OSHA safety standards



Optional time saving carts can be connected to each other, one after another, to create a "train" of carts to further save time and labor. If your building has multiple machines, now you can unload every machine before making a single trip to your collection site.

MODEL	C36RC	C36TC
Overall Height	95" (2,413 mm)	95" (2,413 mm)
Overall Width	52" (1,321 mm)	52" (1,321 mm)
Overall Depth	103" (2,616 mm)	74" (1,880 mm)
Depth with Door Open	135" (3,429 mm)	106" (2,692 mm)
Loading Door Opening	24" x 17" (610 mm x 432 mm)	24" x 17" (610 mm x 432 mm)
Charge Opening	25" x 30" (635 mm x 762 mm)	22" x 29" (559 mm x 737 mm)
Motor	5 horsepower, TEFC	5 horsepower, TEFC
Main Ram Pressure	41,353 lbs. (18,757 kg)	41,353 lbs. (18,757 kg)
Rear Chute Ram Pressure	32,674 lbs. (14,821 kg)	36,758 lbs. (16,673 kg)
Hydraulic Eject Ram Pressure	14,137 lbs. (6,412 kg)	14,137 lbs. (6,412 kg)
Cycle Time	36 seconds	29 seconds
Main Cylinder	4.5" bore (114 mm) 3" rod (76 mm) 33" stroke (838 mm)	4.5" bore (114 mm) 3" rod (76 mm) 33" stroke (838 mm) (twin)
Rear Chute Cylinder	4" bore (102 mm) 2" rod (51 mm) 30.25" stroke (768 mm)	3" bore (76 mm) 2" rod (51 mm) 18" stroke (764 mm) (twin)
Hydraulic Eject Cylinder	3" bore (76 mm) 2" rod (51 mm) 28.25" stroke (718 mm)	3" bore (76 mm) 2" rod (51 mm) 28.25" stroke (718 mm)
Electrical Power	230 volt, 1 phase, 60 hz	230 volt, 1 phase, 60 hz
Pump	Two-stage	Two-stage
Shipping Height	76" (1,930 mm)	76" (1,930 mm)
Shipping Weight	4,360 lbs. (1,978 kg)	2,220 lbs. (1,007 kg)
Installation and Operating Area	50 square feet (4.6 square meters)	50 square feet (4.6 square meters)

Specifications subject to change without notice.



Harmony Enterprises, Inc. 704 Main Avenue North Harmony, MN 55939 USA
 1.800.658.2320 toll free | 1.507.886.6666 international | 1.507.886.6706 fax
 Email us at info@harmony1.com or visit us online at www.harmony1.com

©2009 Harmony Enterprises, Inc. All rights reserved. Form HEI_C36_US 10/09 SC