



BCB2003

Beverage Can Baler

The BCB2003 Beverage Can Baler is the Ideal Solution For:

- Bottlers
- Redemption Centers
- Dairies
- Food Waste Processors
- Scrap Metal Yards
- Cafeterias

The BCB2003 is the first baler of its kind to combine baling and draining both aluminum and plastic containers in one step.

Compare these features of the BCB2003 with the competition:

- The BCB2003 performs over 7 times faster than draining your containers manually
- The total destruction of nearly 2,000 full plastic bottles or 4,000 full aluminum cans in one bale
- 51 gallon reservoir collects the liquids
- A TEFC (Totally Enclosed Fan Cooled) motor allows you to wash the entire machine down

- No preconditioning of material necessary before baling
- The BCB2003 features a "Shark's Teeth" System to ensure maximum liquid removal

The BCB2003 Bottle Can Baler, another great idea from Harmony Enterprises...*The Undisputed Leader in Quality Manufacturing.*



BCB2003 Bottle Can Baler

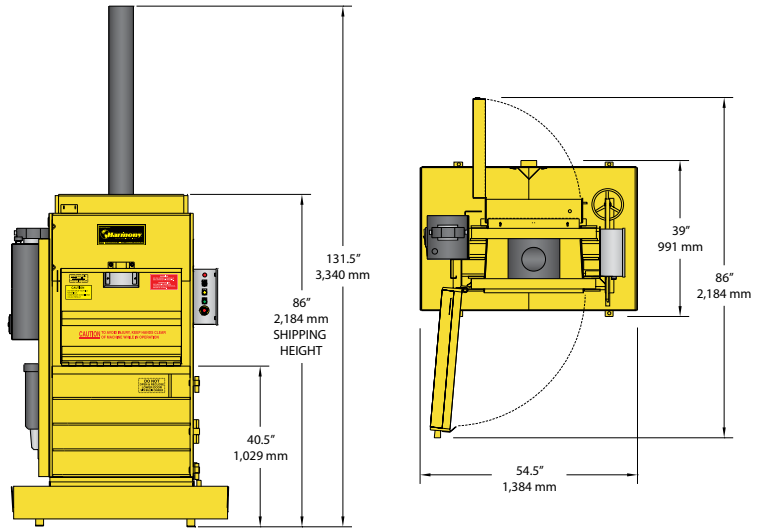

Standard BCB2003 Features:

- Control panel is UL® listed
- Built-in splash guards to help contain liquid
- Magnetically Coded Door switches
- Key operated safety switch
- Sump Pump System to help drain the liquid away to your drain or tote (optional)
- Four slots for tying bales
- 3" drain port allowing you to quickly remove liquids
- 45 second cycle time
- 6" cylinder with 4" rod
- Meets or exceeds all ANSI and OSHA safety standards

SPECIFICATIONS

Bale Size	24" x 16" x up to 24" (610 mm x 406 mm x up to 610 mm)
Bale Weight - Aluminum Cans - Plastic Bottles	up to 120 lbs. (54 kg) up to 230 lbs. (104 kg)
Ram Pressure @ 2,000	56,550 lbs. (25,651 kg)
Cycle Time	45 seconds
Cylinder	6" bore (152 mm) 4" rod (102 mm) 48" stroke (1,219 mm)
Motor	10 horsepower, TEFC
Pump	12 gallon
Liquid Reservoir	51 gallon
Electrical Power	208/230/460 volt, 3 phase, 60 hz
Bale Eject	Hydraulic
Bale Tying	Wire or polyethylene strap

DIMENSIONS

Chute Door Opening	24" x 21" (610 mm x 533 mm)
Overall Height	131.5" (3,340 mm)
Overall Depth	39" (991 mm)
Overall Width	54.5" (1,384 mm)
Depth with Door Open	86" (2,184 mm)
Shipping Height	86" (2,184 mm)
Actual Weight	3,060 lbs. (1,388 kg)
Installation and Operating Area	33 square feet (3 square meters)

Specifications subject to change without notice.



Harmony Enterprises, Inc. 704 Main Avenue North Harmony, MN 55939 USA
 1.800.658.2320 toll free | 1.507.886.6666 international | 1.507.886.6706 fax
 Email us at info@harmony1.com or visit us online at www.harmony1.com

©2009 Harmony Enterprises, Inc. All rights reserved. Form HEI_BCB2003_US 07/09 SC