



compactyre™  
by Harmony Enterprises, Inc.

**Introducing Compactyre,  
The Ultimate Solution To Your  
Scrap-Tire Management Problems.**





## Introducing Compactyre: Harmony Enterprises' Solution to Scrap-Tire Management Problems.

Over 300 million used tires are discarded in the U.S. every year. Some are recycled into ground crumb rubber and used in road way construction, athletic playing surfaces and molded products. They are sometimes used in civil engineering projects or burned as tire-derived fuel.

### Improper Disposal of Used Tires Poses Risk

Health officials have blamed old tires as an indirect source of illnesses like West Nile Virus and Encephalitis. The rainwater that collects in old, unburied tires is an ideal breeding ground for pesky mosquitoes that carry these diseases.

Used tires are bulky, taking up precious storage space at your facility. Some communities even require used tires to be stored indoors, locked in trucks or kept behind fenced and gated areas. Handling and storing old tires adds to the cost of your operation. Hauling and disposal fees are high, and are only going to get higher.

### How Compactyre Works

Harmony Enterprises' solution to help you manage bulky scrap tire waste is Compactyre. Compactyre is a patented, hydraulically driven tire compactor that takes a full-sized tire and compresses it into 1/3 the size. As part of the process, the tire is also punctured in four places and fastened with four metal staples, rendering it unusable. Compactyre is designed for compacting all passenger, light truck and SUV tires.

### Easy To Install

Compactyre has a "footprint" of just 45" x 34" and a maximum operating height of 91", so it will take up very little room in you facility. It is powered by a standard 115/230 VAC single phase circuit, and uses an energy efficient 2 horsepower motor, and whisper quiet hydraulics with a long-life cylinder, to keep operating costs low.

Its vertical design and easy-open, counter-balanced door, makes Compactyre simple to operate. Cycle time for a complete operation is just 15 seconds.

Compactyre meets all ANSI and OSHA safety standards. The control panel is UL® Approved and safety interlock circuitry prevents operation when the door is open.



Cycle time is only 15 seconds.  
The compacted tire, now punctured and pinned in four places, is ready for storage or disposal.



The access door features a self-contained counterweight to make opening and closing the door easy.

Compactyre features safety interlocking circuitry that prevents machine operation when the door is open. Once the door is secured, the operator simply activates the switch and Compactyre goes to work.

The operator places the used tire into the baler. A hydraulic ram is then used to compress the tire, puncture it in 4 places, and drive 3" wire pins through the tire to bind it.

Compactyre has a "footprint" of just 45" x 34" so it takes up very little room on the shop floor.

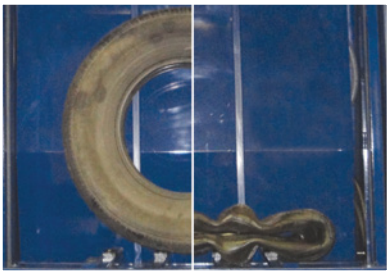

Compactyre reduces bulky scrap tire waste to one third its original size, thus reducing labor and hauling costs.





## Compactyre

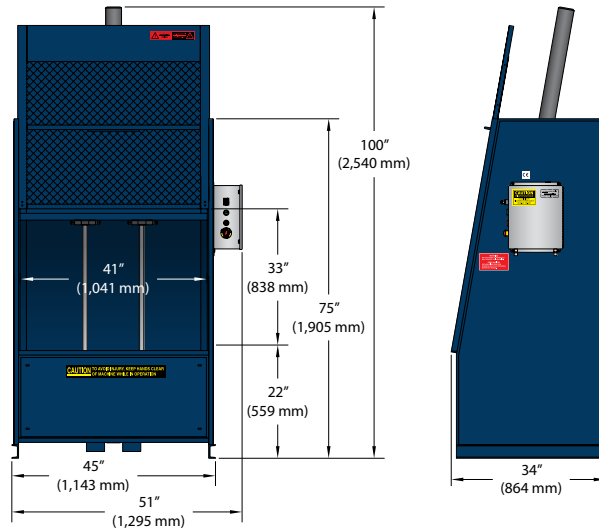

### Standard Compactyre Features:

- Control panel is UL® listed
- Compact, space saving design, operates under a 9' ceiling (100" maximum height)
- Pre-wired at the factory
- Energy efficient motor for low operating cost
- Whisper quiet hydraulics, with long-life cylinder
- Fast 15 second cycle time
- Easy-open, counter-balanced door
- Long-lasting, vane-type pump
- Safety interlock prevents operation when door is open
- Easy to service and maintain
- Meets or exceeds all ANSI and OSHA safety standards

### SPECIFICATIONS

Ram Pressure	18,379 lbs. (8,337 kg)
Cycle Time	15 seconds
Cylinder	3" bore (76 mm) 2" rod (51 mm) 32.25" stroke (819 mm)
Motor	2 horsepower, 1,725 RPM, TEFC
Pump	5.5 gallons
Electrical Power	115/230 volt, 1 phase, 60 hz

### DIMENSIONS

Loading Door Opening	41" x 33" (1,041 mm x 838 mm)
Overall Height	100" (2,540 mm)
Overall Depth	34" (864 mm)
Overall Width	51" (1,295 mm)
Shipping Height	100" (2,540 mm)
Shipping Weight	1,315 lbs. (596 kg)
Installation and Operating Area	11 square feet (1 square meters)

Specifications subject to change without notice.